

CAD FILE:

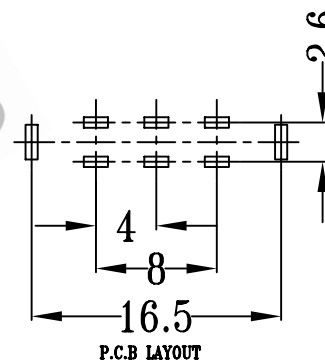
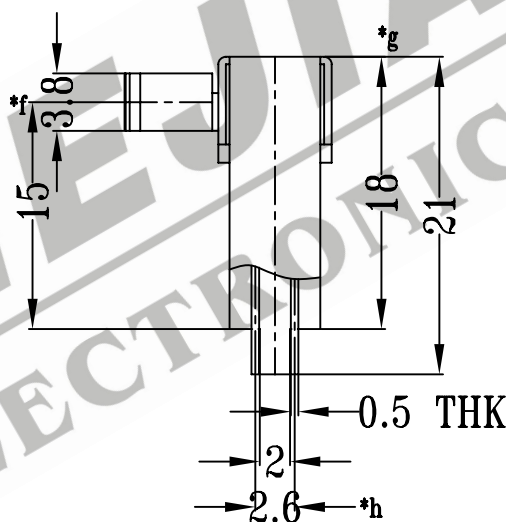
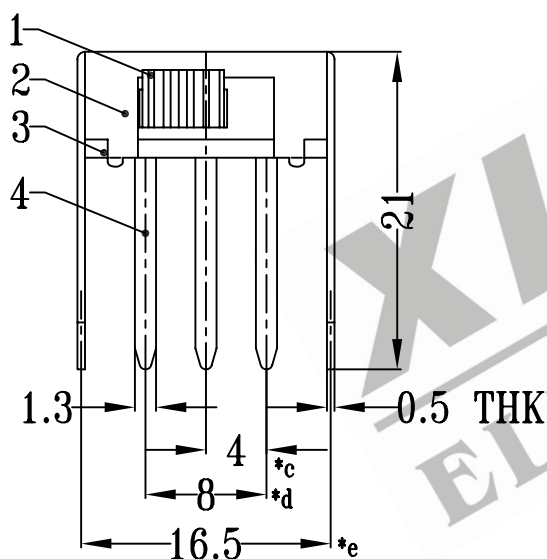
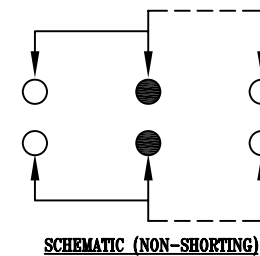
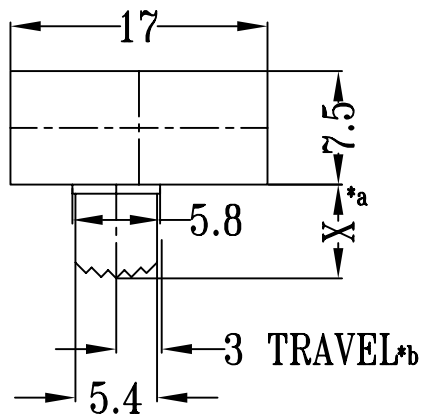

注:带\*表示关键尺寸(8个)

8					TOLERANCE	SHENZHEN XIEJIA ELECTRONICS CO.,LTD.				
7					UNLESS SPECIFIED					
6	SPRING	STEEL WIRE	1	TEMPER	WITHIN: 1.5±0.1mm	ISSUE	DATE	DESCRIPTIONS		APPD.
5	CONTACT	COPPER STRIP	1	Ag PLATED	OVER : 1.5±0.2mm					
4	TERMINAL	BRASS STRIP	6	Ag PLATED OVER Ni PLATED	TITLE : HORIZONTAL SLIDE SWITCH	UNIT : MM		DRWG NO.: XJ-DR-SK22F08-00		
3	BASE	PHENOLIC RESIN	1	BLACK	MODEL: SK-22F08	SCALE: 2:1		DWN.	ZHOUYU	2005-8-9
2	FRAME	STEEL STRIP	1	Ni PLATED				CHK'D	FANGYING	2005-8-9
1	KNOB	POM	1	BLACK	ALL MATERIALS MUST BE COMPLIANT TO ROHS			APPD.	KANGXINAN	2005-8-9
NO.	PART NAME	MATERIAL	Q'TY	FINISHING						